

Steelwork Fabrications



To compliment our standard range of Pipe Hangers and Supports, we have considerable experience in the design and manufacture of steelwork fabrications.

SCOPE

- Secondary Steelwork supporting structures
- Pipe Shoes, Guides, and Anchors
- Adjustable Pipe Supports
- Cantilevers, Goal Posts and associated Frameworks

DESIGN

In addition to manufacturing directly to client specifications, our in-house team can offer a complete design service using Autocad and the latest 3D modelling software packages.

EQUIPMENT

Our fully equipped workshop embraces the latest in fabricating technology including:

- 3.0 kw CNC Laser Profilers (up to 20 mm thick carbon steel)
- Burny 2.5 CNC Gas Profilers (up to 200mm thick carbon steel)
- CNC Vertical Machining Centres
- 400 amp MIG Welding Sets
- Automatic Horizontal Bandsaws up to 400mm section
- Shot Blast Chamber
- Dry Air Filter Spray Booths
- 5 Tonne Overhead Craneage

WELDER QUALIFICATION

All our welders and weld procedures are qualified to both British and European standards, and certified by Lloyds or other similar approved bodies.

PLANNING

We adopt a flexible approach to production planning and work to strict deadlines

QUALITY ASSURANCE

Our Quality Management systems are approved to BS EN ISO 9001. We are also registered on the First Point Assessment registered suppliers list.

MATERIALS

We work with a wide range of materials, typically Carbon Steel, Low Temperature Carbon Steel, Stainless Steel and High Temperature Alloys.

SURFACE COATING

We offer surface finish to client specification ranging from simple primer through to multi-coat systems, all applied in-house. Galvanised and Zinc Plated finishes are available from a local source.

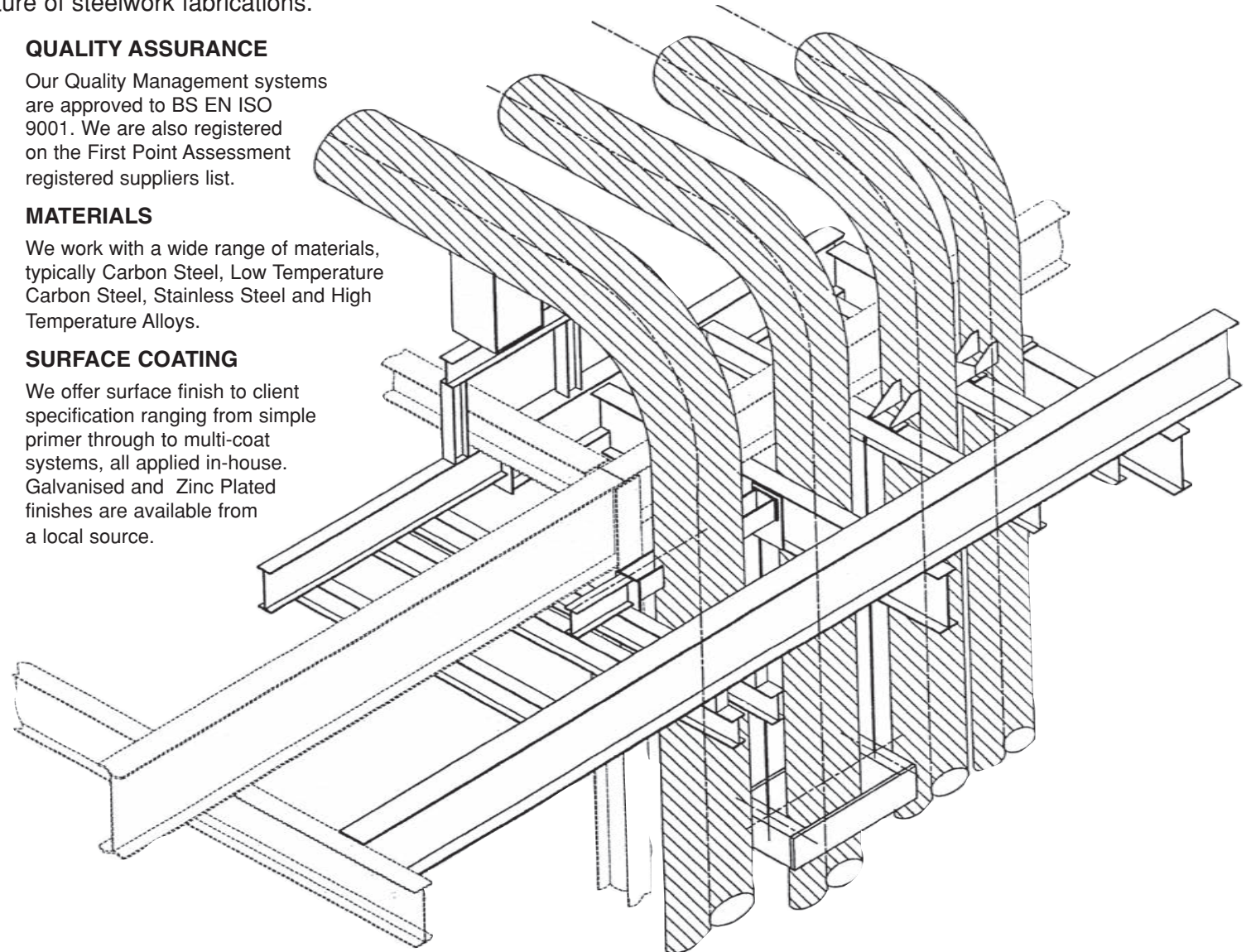

Steelwork Fabrications



Typical fabricated support frame

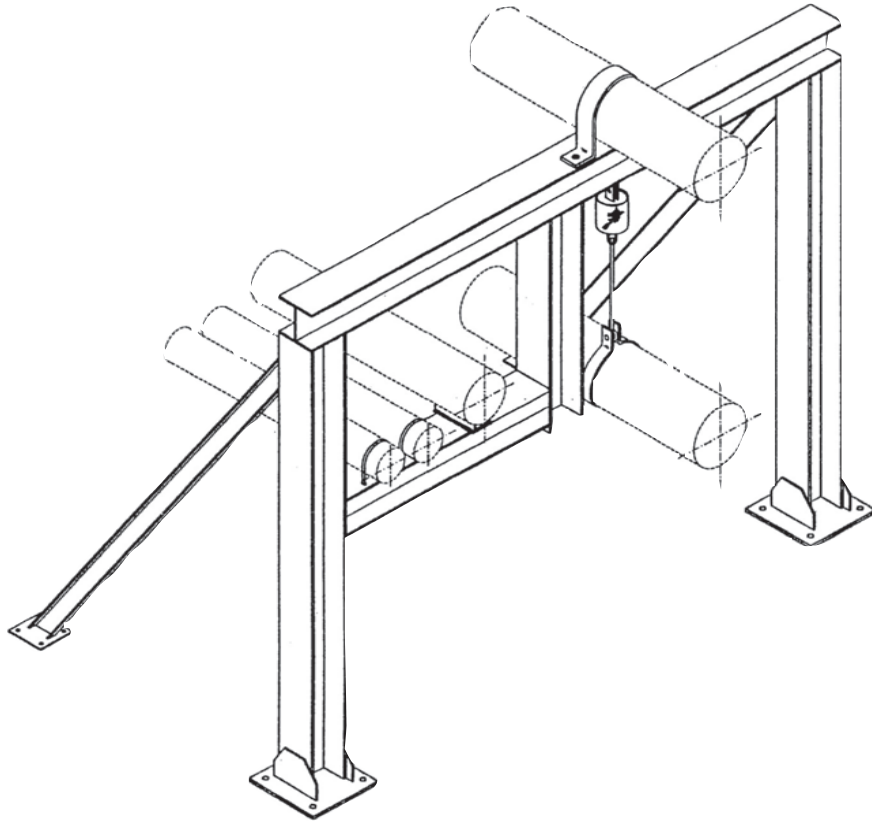

Special support bracket for Tunnel Piping.

